



STRUCTURE ID: 200600

Precast Concrete 2'-0" X 2'-0" X 3'-0"
Electrical Pull Box



Precast Concrete 2'-0" X 2'-0" X 3'-0" Electrical Pull Box :: STRUCTURE ID : 200600

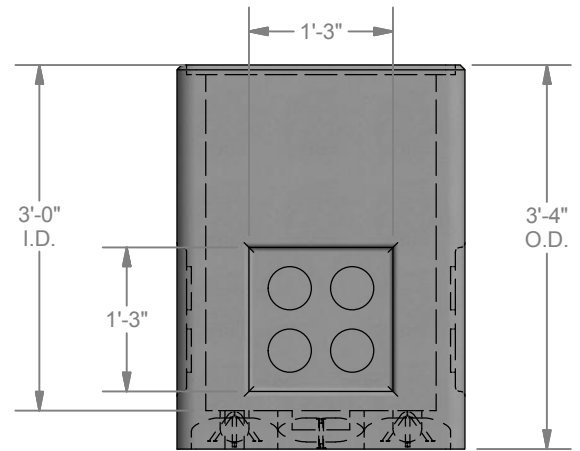
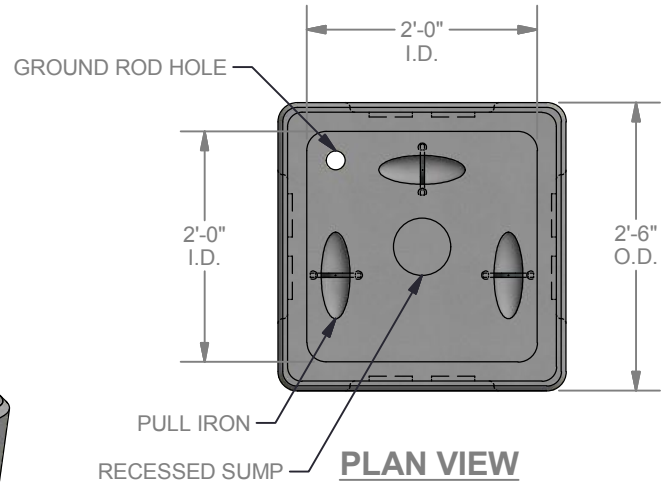
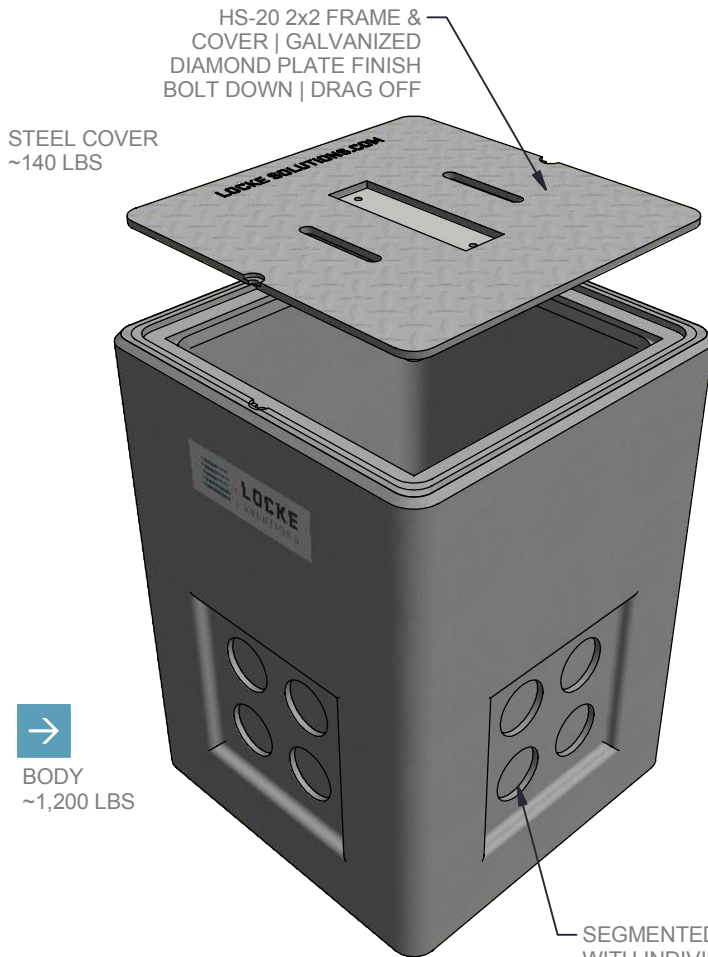

STANDARD PULL BOX FEATURES

- Designed for HS-20 Loading
- Segmented Thin Wall Knockouts (shown)
- Pull Irons Cast In Floor (shown)
- 6" Ø Recessed Sump in Floor (shown)
- 2" Ø Ground Hole in Floor (shown)
- Hot Dipped Galvanized Steel Cover (shown)
- Diamond Plate Finish on Cover (shown)
- Smooth Corners for Safe Installation & Quality &...It Just Looks Better!

PULL BOX OPTIONS

- Unistrut Cast Into Wall for Racking in lieu of Bolt Inserts
- Terminators Cast Into Wall in lieu of Thin Wall Recess
- Non-Metallic Racking
- Plastic Coated Racking
- Cast In Grounding Lug
- Pull Irons - Add or Change Locations
- Aluminum Lld in lieu of Galvanized Steel Lid
- Divider Plate for Multi-Purpose Boxes

LOCKE
SOLUTIONS

PROUDLY BASED IN
HOUSTON, TEXAS

T : 832-804-7062
F : 832-804-7071
E : info@lockesolutions.com

LOCKESOLUTIONS.COM