



STRUCTURE ID: 301300

Precast Concrete 72" Diameter
Drainage Manhole



Precast Concrete 72" Diameter Drainage Manhole :: STRUCTURE ID : 301300

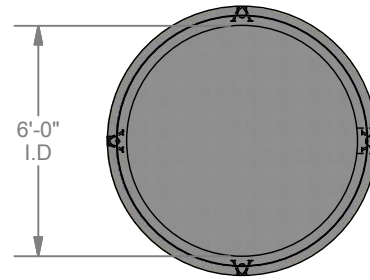
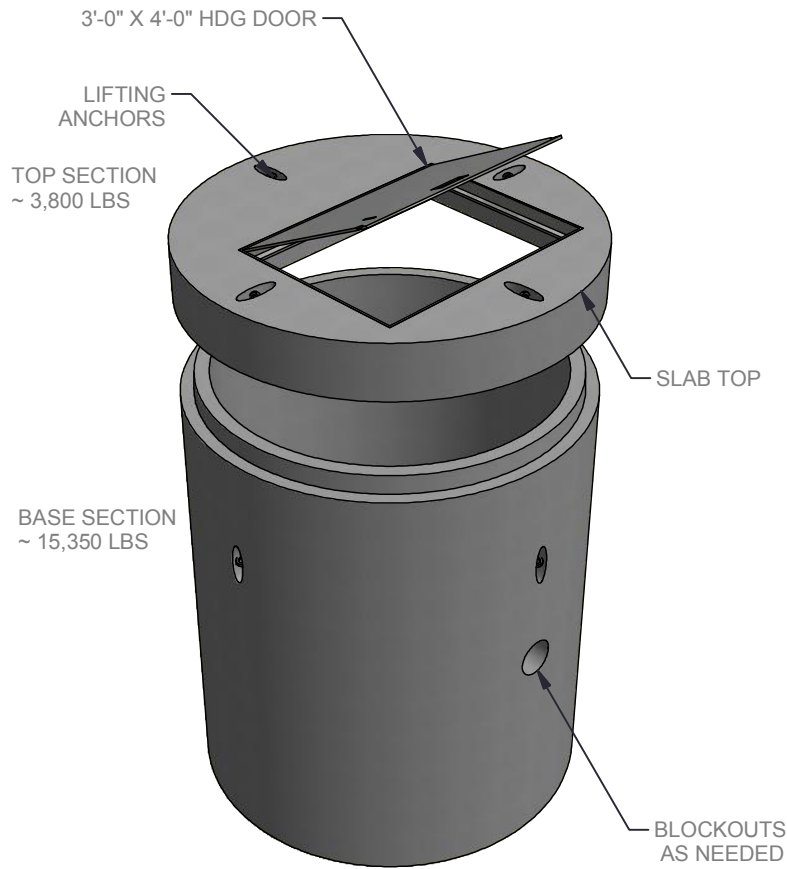

PLAN VIEW (BODY)

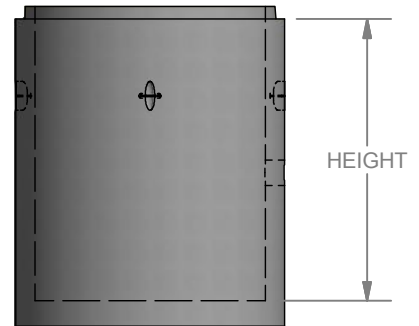
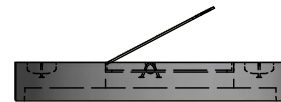

ELEV. VIEW

STANDARD MANHOLE FEATURES

- Designed for HS-20 Loading
- Blockouts As Needed (shown)
- Slab Top with Cast In HDG Door

MANHOLE OPTIONS

- Aluminum Lid in lieu of Galvanized Steel Lid
- Cast Iron Frame and Cover
- Variable Heights

LOCKE
SOLUTIONS

PROUDLY BASED IN
HOUSTON, TEXAS

T : 832-804-7062
F : 832-804-7071
E : info@lockesolutions.com

LOCKESOLUTIONS.COM

