



STRUCTURE ID: 900000

Precast Concrete
Valve Vaults



CONTACT US FOR MORE INFORMATION

Precast Concrete Valve Vaults :: STRUCTURE ID : 900000

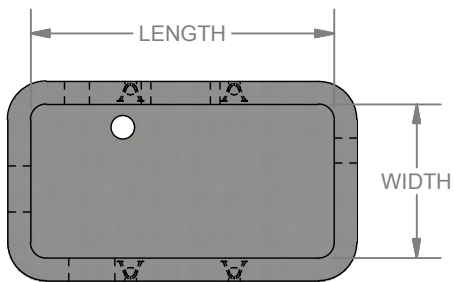
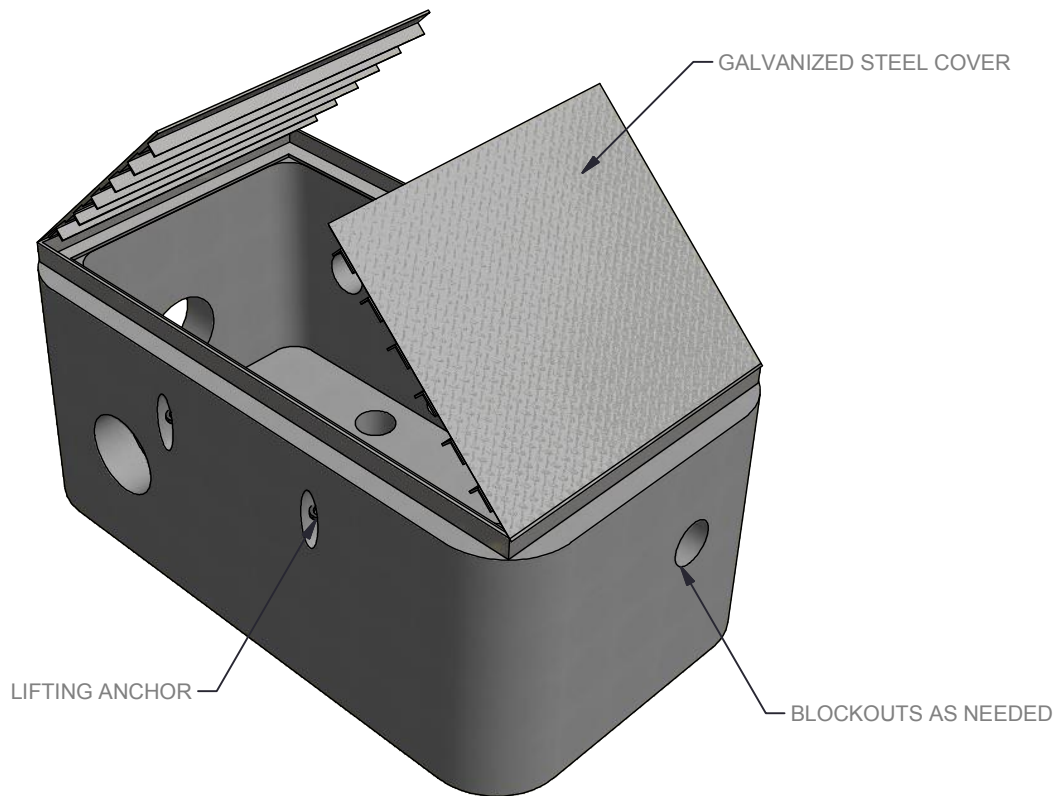

PLAN VIEW

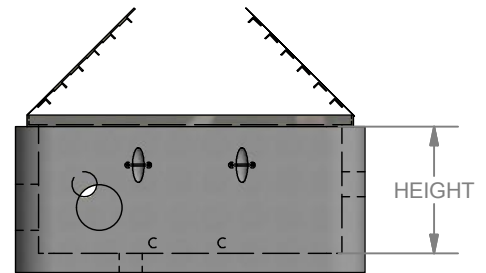

ELEV. VIEW

LOCKE
SOLUTIONS

PROUDLY BASED IN
HOUSTON, TEXAS

T : 832-804-7062
F : 832-804-7071
E : info@lockesolutions.com

LOCKESOLUTIONS.COM

