



STRUCTURE ID: E100

12" Diameter  
**M.A. Industries Plastic Sump**



12" Diameter M.A. Industries Plastic Sump ... STRUCTURE ID : E100

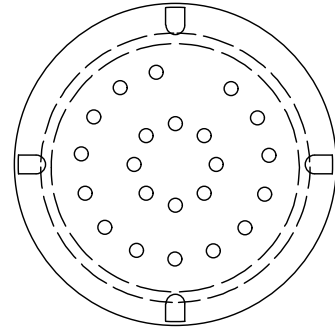

**PLAN VIEW**

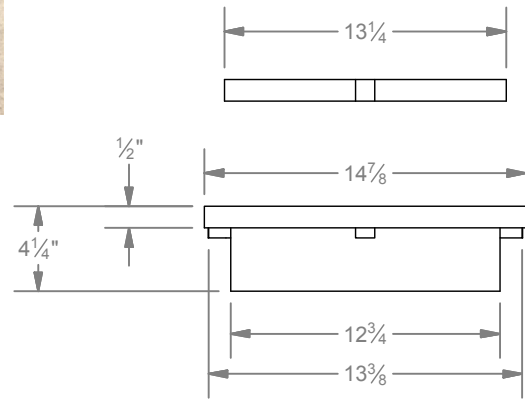

**ELEV. VIEW**

**INFORMATION:**

- High Strength Quality Plastic; Corrosion Free
- M.A. Sump Pans Are Designed So The Lid Lockes To The Pan Keeping It Securely In Place. Removal Of The Lid Is Accomplished By Snaping The Lid Out Of The Pan With A Screwdriver And Replacing It By Simply Pressing It Into Place With Your Hand.

**LOCKE**  
SOLUTIONS

PROUDLY BASED IN  
HOUSTON, TEXAS

T : 832-804-7062  
F : 832-804-7071  
E : info@lockesolutions.com

[LOCKESOLUTIONS.COM](http://LOCKESOLUTIONS.COM)

